

SSWF-S01-AE11-(HWH)-C20

SUNTSU

SWITCH

FOOT SWITCH

SERIES NUMBER

SWITCH FUNCTION
A : SPST OFF-(ON)

TERMINAL CODE
11 : Wire

BUSHING AND BUTTON SPEC
E : Button 10.0Ø, Bushing 14.3mm

ACCESSORIES

H : Hex Nut
W : Spring Washer
*In Bulk

CONNECTOR
C20 : W/ Connector
Pitch 2.0mm

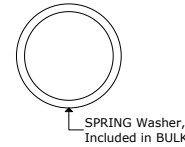
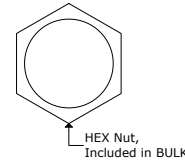
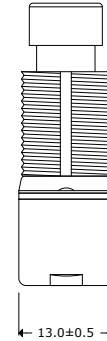
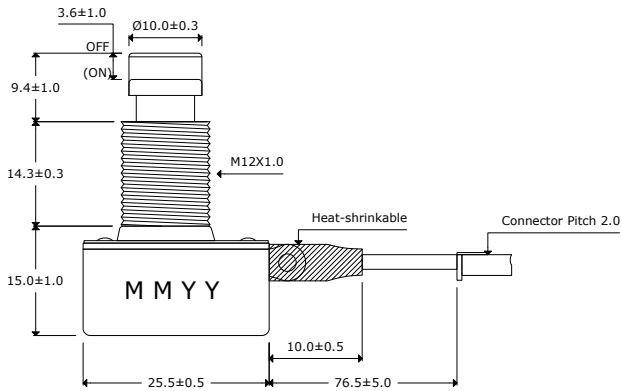
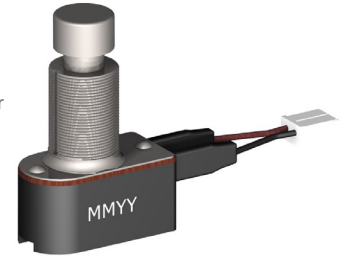

Test Circuit

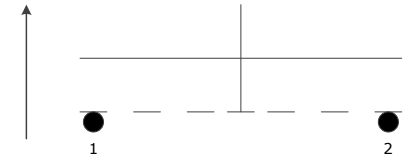

Mounting Hole

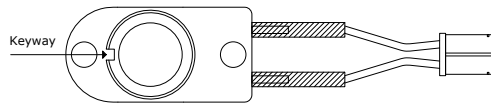
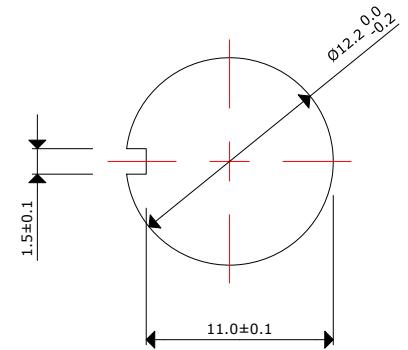

Top View

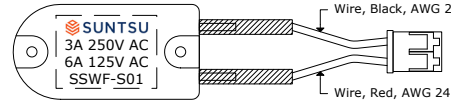

Bottom View

Electrical Parameters:

- Rating: 6A 125V AC, 3A 250VAC
- Contact Resistance: 50mΩ Max
- Insulation Resistance: DC 500V 100MΩ Min.
- Dielectric Strength: AC 1500V 1 minute
- Operation Temperature: -20°C ~ 65°C
- Switch Function: 2P SPST OFF-(ON), PUSH ON
- Accessories: 2 HEX Nut & 1 SPRING Washer in BULK

Materials:

- Frame: Black, PF
- Actuator: Ni-plated, Brass
- Terminals: Silver plated, Copper Alloy

Remarks:

- 500pcs per master carton
- Electrical life 20,000 cycles
- Mechanical life 100,000 cycles



Momentary Foot Switch

Document History			
Edits Made	Date	Edited By	Approved By
Initial Release	09/07/2021	B. Gibbons	KH Mun

Part No.	SSWFS-S01-AE11-(HWH)-C20	Drawn	B. Gibbons 09/07/2021
Scale	Not drawn to scale	Tolerance	
Unit	mm	Pages	1/1