

Aug.1.2022 Copyright 2022 HIROSE ELECTRIC CO., LTD. All Rights Reserved.  
In case of consideration for using Automotive equipment / device which demand high reliability, kindly contact our sales window correspondents.

Notes. 1. Recommended cable condition is shown below.  
 ⚠ A list of compatible cables is available on the Hirose website.  
 When using a non-recommended cable, please contact a Hirose sales representative.  
 Refer to the technical specification (ETAD-E3213) for wiring and assembly procedures.

⚠ Recommended Cable

Items		⚠ Recommended Condition
Conductor	Size	AWG#28 to 26
	Composition	7 stranded
	Material	Annealed copper wire
Insulation O.D.		φ 0.95 to 1.05mm
Braid Shield		Tin plating
Sheath O.D.		φ 6.3 to 7.2mm

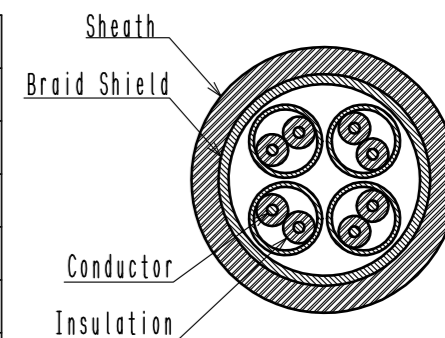

② This product (Type A) is defined for 10/100 Mbit/s and 1/10 Gbit/s Ethernet communication. Please use Type B for all other non Ethernet applications like signaling, serial or other industrial bus communication systems.

⚠ Mating Key

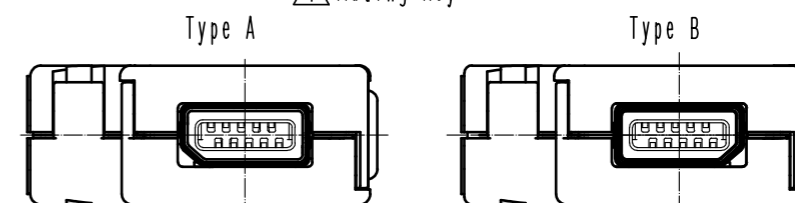

③ Excluding the plug unit, this product is packaged separately by the type of parts. The shield shell is packaged prior to bending. (See next page.) Refer to the technical specification (ETAP-E3224) for packing.

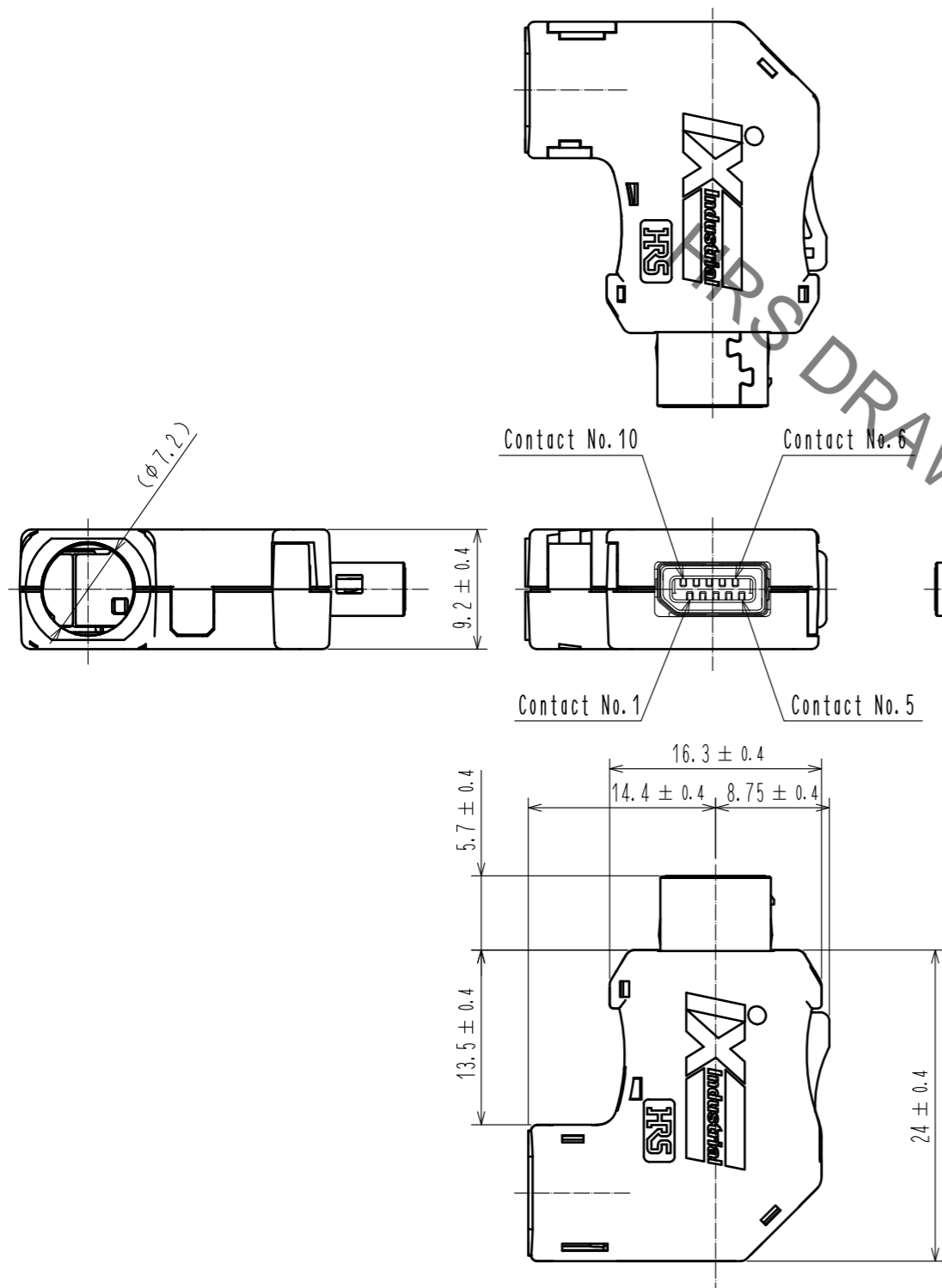

NO.	MATERIAL	FINISH . REMARKS	NO.	MATERIAL	FINISH . REMARKS
4	PA	Black. UL94V-0	9	PC	Dark gray. UL94V-0
3	Stainless Steel		8	PC	Dark gray. UL94V-0
2	PA	Black. UL94V-0	7	Stainless Steel	Nickel 0.2 μm min
1	Copper Alloy	Contact area : Palladium-Nickel 0.75 μm min + Gold 0.05 μm min Wiring area : Gold 0.03 μm min Under plating : Nickel 2 μm min	6	Stainless Steel	Nickel 1 μm min
			5	PC	Clear. UL94V-0

UNITS	SCALE	COUNT	DESCRIPTION OF REVISIONS	DESIGNED	CHECKED	DATE
mm	2 : 1	6	DIS-E-00006876	MT. YASUDA	KI. KAGOTANI	20210922

APPROVED	CHECKED	DESIGNED	DRAWN	DRAWING NO.	PART NO.	CODE NO.
MN. KENJO	KI. NAGANUMA	MT. YASUDA	MY. KOMUKAI	EDC-129974-01-00	IX30G-A-10S-CVL1(7.0)(C1)	CL0251-0063-0-01
20200521	20200521	20200521	20200520			

Aug.1.2022 Copyright 2022 HIROSE ELECTRIC CO., LTD. All Rights Reserved.  
In case of consideration for using Automotive equipment / device which demand high reliability, kindly contact our sales window correspondents.

2 Pin Assignment For 10/100 Mbit/s And 1/10 Gbit/s Ethernet

Contact No.	Signal	
	10/100 Mbit/s	1/10 Gbit/s
1	TX+	BI_DA+
2	TX-	BI_DA-
3	N.C	N.C
4	N.C	BI_DC+
5	N.C	BI_DC-
6	RX+	BI_DB+
7	RX-	BI_DB-
8	N.C	N.C
9	N.C	BI_DD+
10	N.C	BI_DD-

3 Shield Shell Delivery Form

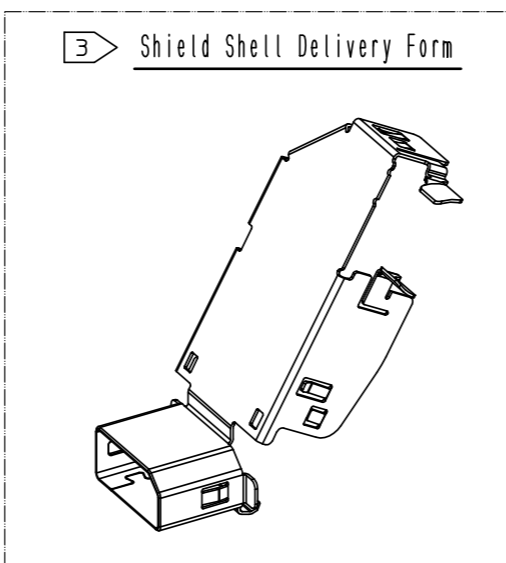

3 Product Structure

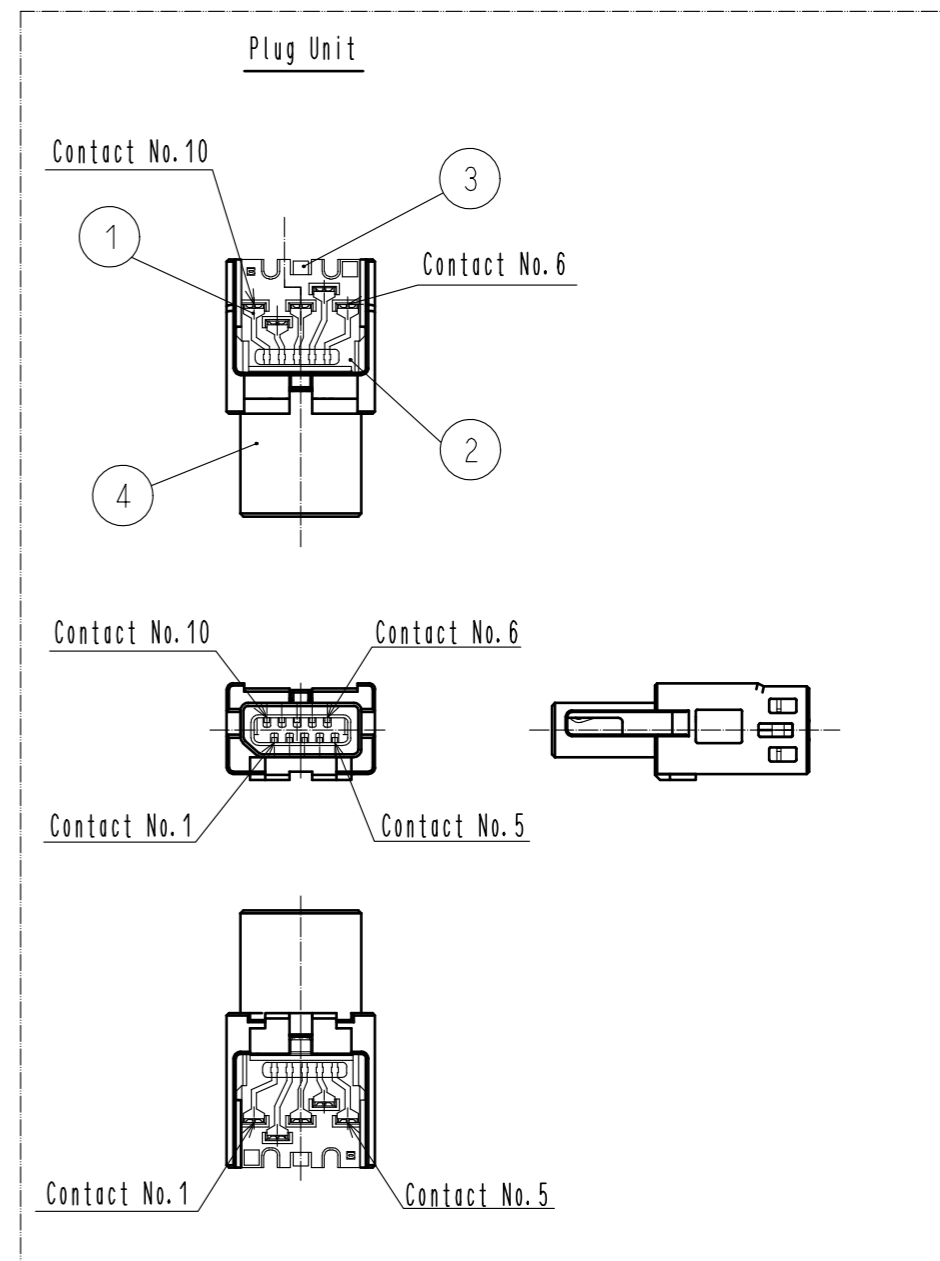
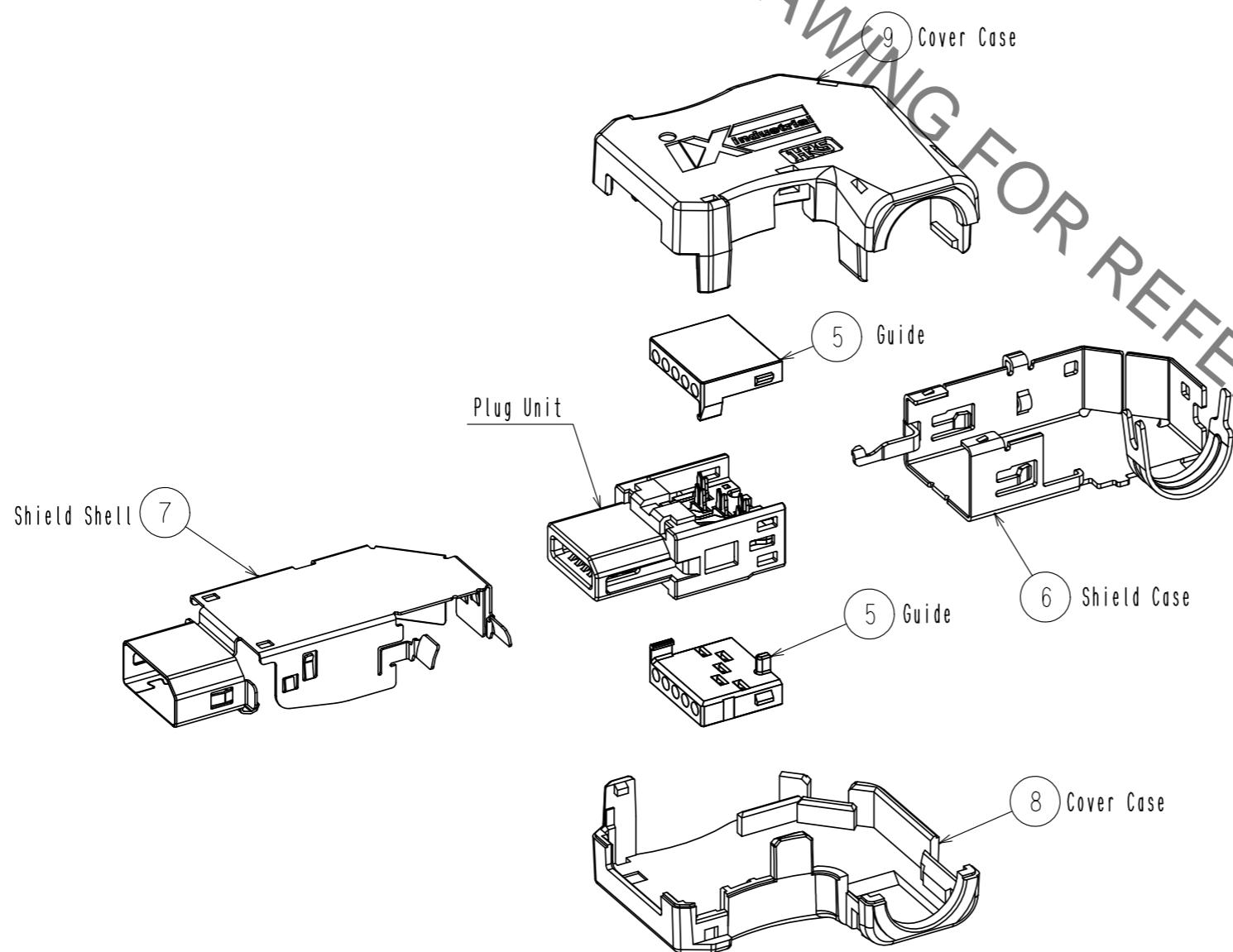

Mated Condition

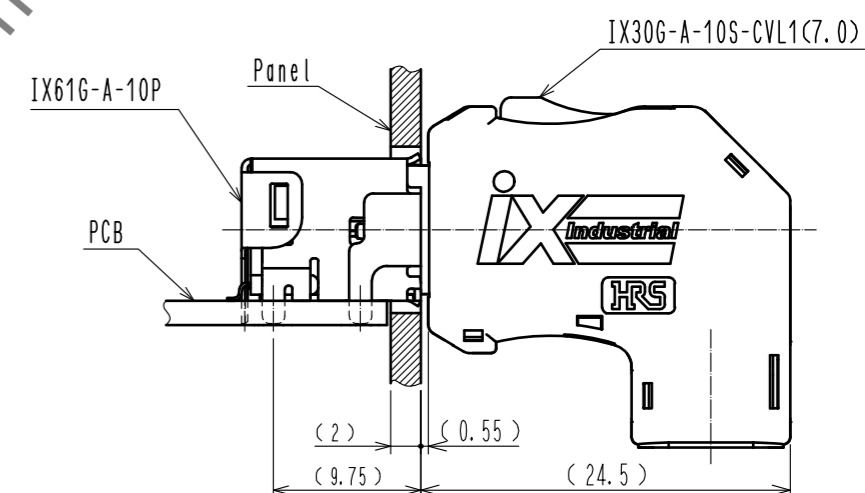

<b>HRS</b>	DRAWING NO.	EDC-129974-01-00
	PART NO.	IX30G-A-10S-CVL1(7.0)(01)
	CODE NO.	CL0251-0063-0-01
		1/2