



P-DUKE POWER

TAD65-P Series

AC-DC POWER SUPPLIES
Up to 65 Watts

3
YEARS
WARRANTY

ROHS
COMPLIANT

REACH
COMPLIANT

+85°C
-40°C
AMBIENT TEMP.



Automation



Datacom



IPC



Industry



Measurement



Telecom



Automobile



Boat



Charger



Medical



PV



Railway

UL US CB CE UK CA

FC POWER SAVE

PEAK
POWER

3000
VAC
Reinforced
Insulation

ADJ.
Output
Voltage

Internal
EN55032
Class
Filter **B**

LOW
Standby
Power

LOW
Leakage
Current

Operating
Altitude
5000
meter

Protection
Class I
Class II

OCP

OVP

SCP

PART NUMBER STRUCTURE

T	A	D	65	U	S	12	C	-			
Application	Package Code	Dimension Code	Output Power (W)	Input Voltage (VAC)	Output Quantity	Output Voltage (VDC)	Protection Type		Connector Options	Peak Power Support Options	Conformal Coating Options
Industry Application	A: Open type U: U chassis type E: Enclosed type D: Din rail type			U: Universal 85 ~ 264	S: Single	05:5 7P5:7.5 09:9 12:12 15:15 18:18 24:24 241:24 28:28 281:28 36:36 48:48 53:53	C: CLASS I D: CLASS II		□: JST M: Molex T: Terminal Block	□: None P: Peak Power	□: None R: Conformal Coating

TECHNICAL SPECIFICATION All specifications are typical at 230VAC input, full load and 25°C unless otherwise noted

Model Number	Input Range	Output Voltage	Output Current Natural Convection	Max. Output Power	Max. Peak Power	Input Power @ No Load	Efficiency	Maximum Capacitor Load
	VAC	VDC	A	W	W	W	%	μF
TAD65US05C-P TUD65US05C-P TED65US05C-P TDD65US05C-P	85 ~ 264	5	10	50	65	0.11	90	20000
TAD65US7P5C-P TUD65US7P5C-P TED65US7P5C-P TDD65US7P5C-P	85 ~ 264	7.5	8.67	65	90	0.11	90	11560
TAD65US09C-P TUD65US09C-P TED65US09C-P TDD65US09C-P	85 ~ 264	9	7.23	65	90	0.11	91	8033
TAD65US12C-P TUD65US12C-P TED65US12C-P TDD65US12C-P	85 ~ 264	12	5.42	65	90	0.11	92.5	4520
TAD65US15C-P TUD65US15C-P TED65US15C-P TDD65US15C-P	85 ~ 264	15	4.34	65	90	0.11	93.5	2900
TAD65US18C-P TUD65US18C-P TED65US18C-P TDD65US18C-P	85 ~ 264	18	3.62	65	90	0.11	93.0	2015
TAD65US24C-P TUD65US24C-P TED65US24C-P TDD65US24C-P	85 ~ 264	24	2.71	65	90	0.11	93.5	1130
TAD65US241C-P TUD65US241C-P TED65US241C-P TDD65US241C-P	85 ~ 264	24	2.71	65	90	0.11	92	1130
TAD65US28C-P TUD65US28C-P TED65US28C-P TDD65US28C-P	85 ~ 264	28	2.33	65	90	0.11	93.5	830
TAD65US281C-P TUD65US281C-P TED65US281C-P TDD65US281C-P	85 ~ 264	28	2.33	65	90	0.11	91.5	830
TAD65US36C-P TUD65US36C-P TED65US36C-P TDD65US36C-P	85 ~ 264	36	1.81	65	90	0.11	92.5	520
TAD65US48C-P TUD65US48C-P TED65US48C-P TDD65US48C-P	85 ~ 264	48	1.36	65	90	0.11	93	285
TAD65US53C-P TUD65US53C-P TED65US53C-P TDD65US53C-P	85 ~ 264	53	1.24	65	90	0.11	92.5	235

INPUT SPECIFICATIONS					
Parameter	Conditions	Min.	Typ.	Max.	Unit
Operating input voltage range	AC input	85		264	VAC
	DC input	120		370	VDC
Input frequency	AC input	47		63	Hz
Input current	100VAC and Full Load			1.6	A
	240VAC and Full Load			0.9	
No load input power	230VAC		0.11		mW
Leakage current	264VAC		75		μA
Start up time				1000	ms
Rise time			20		ms
Hold up time	115VAC and Full Load		16		ms
Input inrush current	230VAC		60		A
Input protection	Internal fuse			T3.15A/250VAC	

OUTPUT SPECIFICATIONS						
Parameter	Conditions	Min.	Typ.	Max.	Unit	
Output power	Full Load			65	Watts	
Output peak power	Peak power			65	Watts	
	Peak power	5Vout		90	Watts	
	Peak power time	Others				
	Peak power duty		5		S	
	Average operation power (% of Full Load)		20		%	
Initial set voltage accuracy	230VAC and Full Load	-1.0		+1.0	%	
Line regulation	Low Line to High Line at Full Load	-0.2		+0.2	%	
Load regulation	No Load to Full Load	5Vout		+0.7		
		Others		+0.5	%	
	10% Load to 90% Load	5Vout	-0.6		+0.6	
		Others	-0.4		+0.4	
Voltage adjustability		-20		+10	%	
Minimum load			0		%	
Ripple and noise	Measured by 20MHz bandwidth					
	With a 10μF/25V 1206 X7R MLCC	5Vout, 7.5Vout, 9Vout		75	mVp-p	
		12Vout, 15Vout, 18Vout				
	With a 1μF/50V 1206 X7R MLCC	24Vout, 28Vout, 36Vout		75		
With a 0.1μF/100V 1206 X7R MLCC	48Vout, 53Vout		150			
Temperature coefficient		-0.02		+0.02	%/°C	
Transient response	Load step from 50 ~ 75% change at 2.5A/μs	Peak deviation		3	%Vout	
		Recovery time		600	μs	
Over voltage protection	% of Vout(nom); Automatics recovery	125		140	%	
Over load protection	% of Iout rated; Hiccup mode		165		%	
Short circuit protection					Continuous, automatics recovery	

GENERAL SPECIFICATIONS					
Parameter	Conditions	Min.	Typ.	Max.	Unit
Isolation voltage	1 minute (Reinforced insulation)	Input to Output		3000	VAC
		Input (Output) to F.G.		2500	
Isolation resistance	500VDC	0.1			GΩ
Switching frequency	230VAC	5Vout		60	kHz
		7.5Vout		110	
		9Vout		90	
		Others		120	
Safety approvals	IEC/ EN/ UL 62368-1				UL:E193009 CB:UL(Demko)
Weight	TAD				117g (4.13oz)
		TUD			157g (5.54oz)
		TED			172g (6.07oz)
		TDD			193g (6.81oz)
MTBF	MIL-HDBK-217F, Full load				1.494 x 10 ⁶ hrs

ENVIRONMENTAL SPECIFICATIONS

Parameter	Conditions	Min.	Typ.	Max.	Unit
Operating ambient temperature	Natural convection With derating	-40		+85	°C
Storage temperature range		-40		+85	°C
Operating altitude				5000	m
Shock					IEC60068-2-27
Vibration					IEC60068-2-6
Relative humidity	Non-condensing				5% to 95% RH

EMC SPECIFICATIONS

Parameter	Conditions	Level	
EMI	EN55032 and FCC Part 15	Conducted	Class B
	External components may be required for class I application.	Radiated	Class B
Harmonic currents	EN61000-3-2 Full Load		Class A
Voltage flicker	EN61000-3-3		
EMS	EN55035 and Complies with EN61850-3		
ESD	EN61000-4-2		Perf. Criteria A
Radiated immunity	EN61000-4-3 20 V/m		Perf. Criteria A
Fast transient	EN61000-4-4 ± 4KV		Perf. Criteria A
Surge	EN61000-4-5 DM ± 2kV and CM ± 4kV		Perf. Criteria A
Conducted immunity	EN61000-4-6 20 Vr.m.s		Perf. Criteria A
Power frequency magnetic field	EN61000-4-8 100 A/m		Perf. Criteria A
Dip and interruptions	EN61000-4-11		
Damped Oscillatory Wave	EN61000-4-18 DM ± 1kV and CM ± 2.5kV		Perf. Criteria A

CHARACTERISTIC CURVE

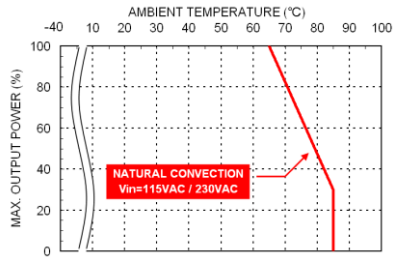

TAD65 & TUD65 Derating Curve vs. Ambient Temperature

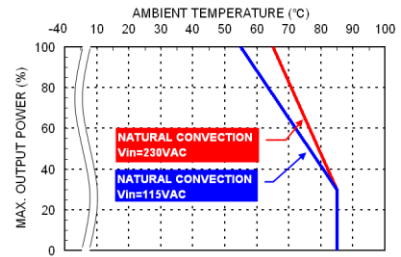

TED65 & TDD65 Derating Curve vs. Ambient Temperature

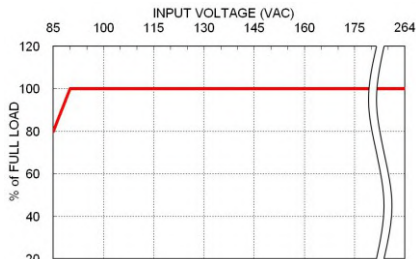

Derating Curve vs. Input Voltage

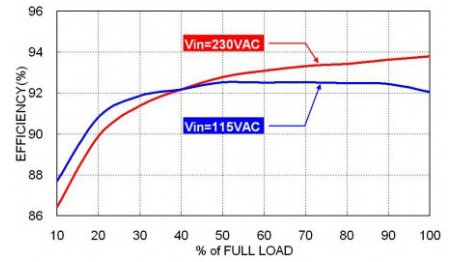

T D65US24C-P Efficiency VS Output Load

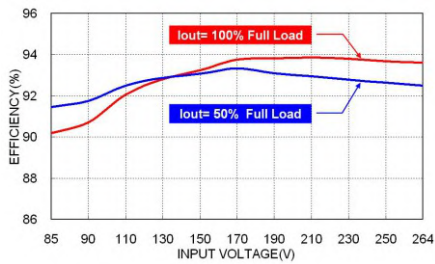

T D65US24C-P Efficiency VS Input Voltage

MECHANICAL DRAWING

TAD Open type

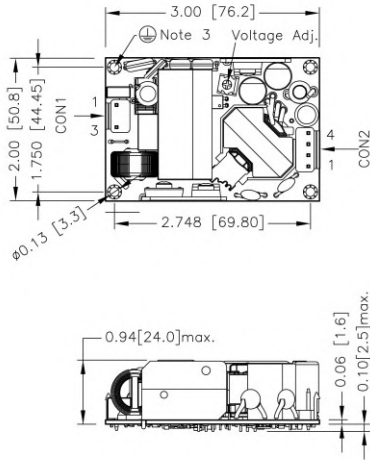

FRONT VIEW

1. All dimensions in inch [mm]
Tolerance : $x.xx \pm 0.02$ [$x.x \pm 0.5$] $x.xxx \pm 0.010$ [$x.xx \pm 0.25$]
2. The screw locked torque: MAX 5.0kgf-cm/0.49N-m
3. The screws holes can be considered as PE connection for CLASS I application.

TDD Din rail type

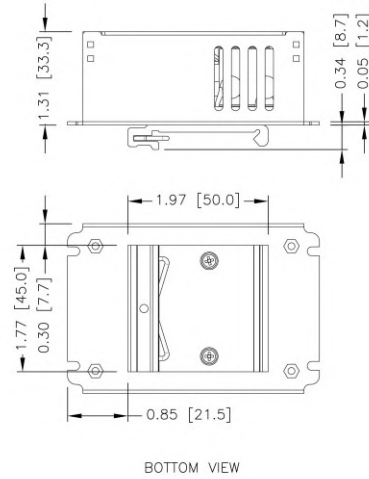

BOTTOM VIEW

1. All dimensions in inch [mm]
Tolerance : $x.xx \pm 0.02$ [$x.x \pm 0.5$] $x.xxx \pm 0.010$ [$x.xx \pm 0.25$]

TED Enclosed type

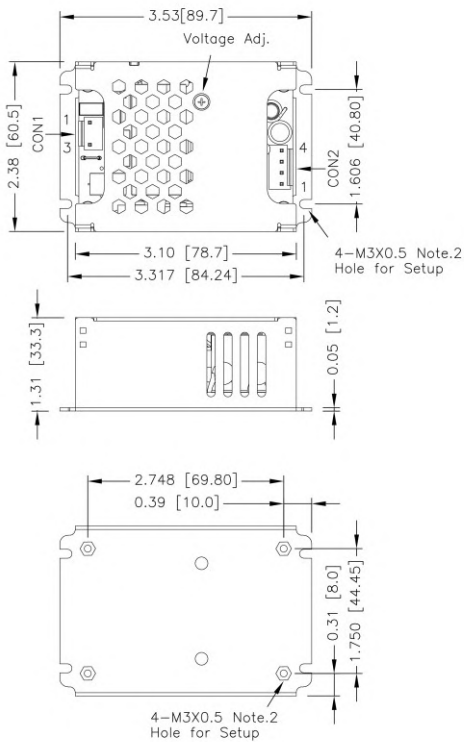

BOTTOM VIEW

1. All dimensions in inch [mm]
Tolerance : $x.xx \pm 0.02$ [$x.x \pm 0.5$] $x.xxx \pm 0.010$ [$x.xx \pm 0.25$]
2. The screw locked torque: MAX 5.0kgf-cm/0.49N-m

TUD U chassis type

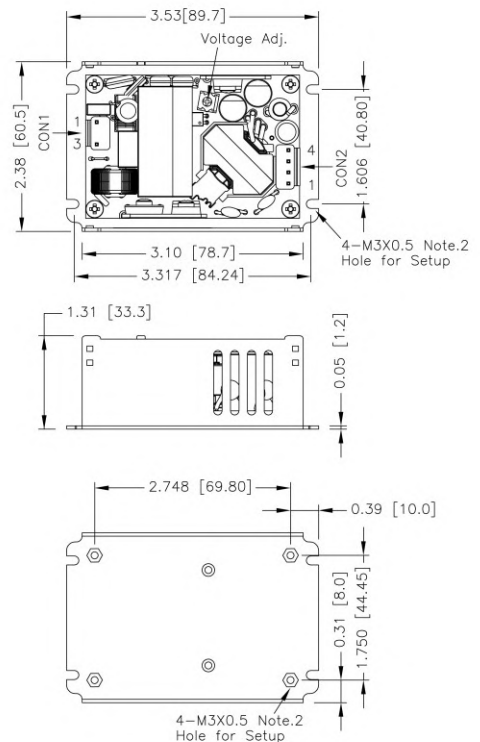

BOTTOM VIEW

1. All dimensions in inch [mm]
Tolerance : $x.xx \pm 0.02$ [$x.x \pm 0.5$] $x.xxx \pm 0.010$ [$x.xx \pm 0.25$]
2. The screw locked torque: MAX 5.0kgf-cm/0.49N-m

CONNECTOR CONNECTIONS

CON1 – Input Connector

Pin 1	Line
Pin 3	Neutral

CON2 – Output Connector

Pin 1,2	-Vout
Pin 3,4	+Vout

*Either one of four screws holes of Chassis type can be considered as PE connection for CLASS I application.

CONNECTOR OPTIONS

Blank:

JST Type

Housing

CON1: **VHR-3N**

CON2: **VHR-4N**



Crimp terminals

CON1: **SVH-21T-P1.1**

CON2: **SVH-21T-P1.1**

-M

Molex Type

Housing

CON1: **09-50-8031**

CON2: **09-50-8041**



Crimp terminals

CON1: **SD-2478**

CON2: **SD-2478**

-T

Terminal Block

Mates with

**Screw locked torque
MAX 2Kgf.cm/0.2N.m**



Wire dimension range

26 ~ 16AWG